

凸輪軸感知器

曲軸感知器

爆震感知器

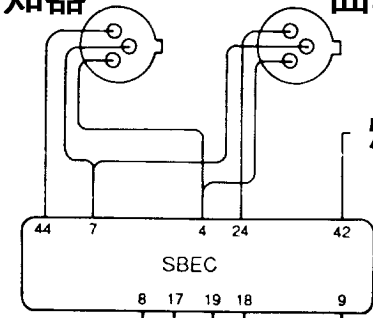
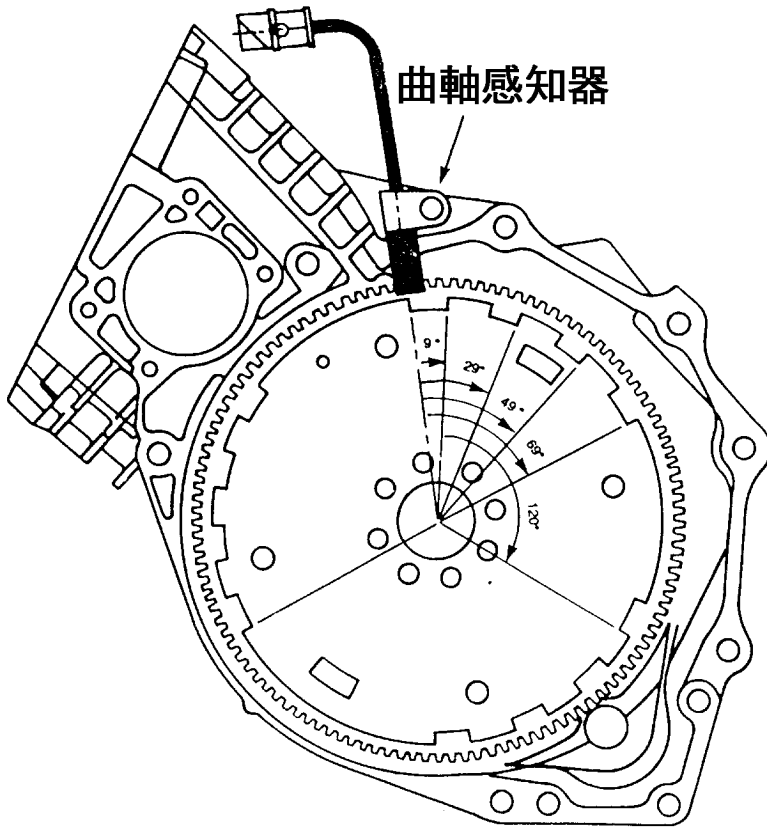

電源 IGN

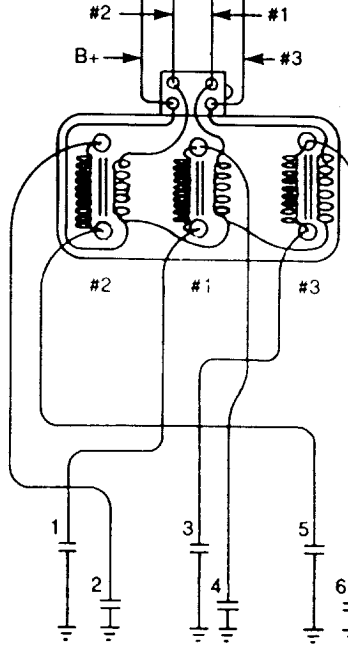

點火線圈組

火星塞

0390154

- 0 CAM PULSES, 4 CRANK PULSES = #1 TDC, COIL #1, #3 INJECTOR PAIR (INJ 4 & 5)
- 1 CAM PULSE, 4 CRANK PULSES = #2 TDC, COIL #2
- 2 CAM PULSES, 4 CRANK PULSES = #3 TDC, COIL #3, #1 INJECTOR PAIR (INJ 1 & 6)
- 3 CAM PULSES, 4 CRANK PULSES = #4 TDC, COIL #1
- 1 CAM PULSE, 4 CRANK PULSES = #5 TDC, COIL #2, #2 INJECTOR PAIR (INJ 2 & 3)
- 2 CAM PULSES, 4 CRANK PULSES = #6 TDC, COIL #3

曲軸信號

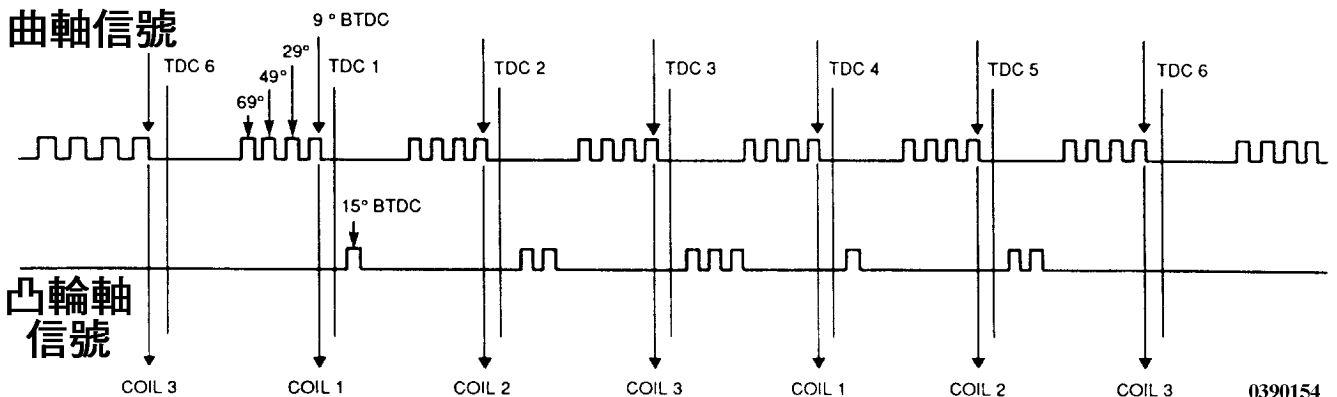

0390154